

**LIVINGSTON COUNTY ROAD COMMISSION**

***SPECIFICATIONS AND ADMINISTRATIVE  
RULES REGULATING  
DRIVEWAYS, ROAD APPROACHES,  
BANNERS AND PARADES  
ON AND OVER HIGHWAYS***

**Adopted by the Board of County Road Commissioner  
November 12, 1988  
Effective January 1, 1999**

*TABLE OF CONTENTS*

	<u>Page</u>
GENERAL REQUIREMENTS FOR APPROACH PERMITS .....	1
RESIDENTIAL DRIVEWAY APPROACHES .....	3
FIELD DRIVEWAY APPROACHES .....	7
COMMERCIAL DRIVEWAY APPROACHES .....	8
PUBLIC AND PRIVATE ROAD APPROACHES .....	13
RECREATIONAL (CELEBRATIONS AND FESTIVAL) DRIVEWAY APPROACHES .....	18
ROAD CLOSURES FOR PARADES, CELEBRATIONS AND FESTIVALS .....	19
BANNER PERMITS .....	20
VARIANCE IN STANDARDS .....	22
VALIDITY .....	22
APPENDIX A - TYPICAL DESIGN STANDARDS .....	A.1

*GENERAL REQUIREMENTS FOR APPROACH PERMITS*

## Rules and Authority

Act 200 of the Public Acts of 1969, Section 4 thereof, charges the highway authority with the responsibility to issue driveway permits consistent with the rules promulgated by the highway authority for public safety and in the public interest.

Any work to be accomplished within the right-of-way of any road under the jurisdiction of the Board of County Road Commissioners of Livingston County, Michigan requires a permit before commencement of such work. The applicant or his agent shall have a copy of the permit at the site during construction.

Permits for access onto a county road will be issued only on forms that are approved by the Board. Such permit forms are available at the office of the Livingston County Road Commission at 3535 Grand Oaks Drive, Howell, Michigan 48843.

The applicant, owner or person responsible for operation of any permitted approach shall maintain in perpetuity all conditions set forth in the permit and required in these specifications, and as may be amended.

When the type or volume of traffic using an existing driveway changes to a more intensified classification because of a change in land use or roadside development, the party responsible for operation of the driveway shall be required to obtain a permit and improve the driveway or driveways to the standards contained herein.

The applicant or his agent shall undertake all necessary precautions to prevent injury or damage to persons and property from operations covered by the permit and shall use warning signs and safety devices which are in accordance with the current Michigan Manual of Uniform Traffic Control Devices.

In the event of a failure to comply with the terms and conditions of any permit issued in accordance with these rules or failure to obtain an appropriate permit, the Livingston County Road Commission shall have the right to halt such activity until such time that adequate compliance is made. All costs incurred by the Board in correcting 1) a failure to comply with conditions and standards of a permit, 2) a failure to obtain a permit, or 3) defective workmanship or materials, shall be borne by the applicant (or person undertaking the activity).

These specifications apply to county road right-of-ways under the jurisdiction of the Livingston County Road Commission. These specifications shall not supersede any standards of local townships, cities, villages, or the Michigan Department of Transportation. However, at times these specifications may be more restrictive than standards established by other agencies. In all cases, the applicant will be required to fully comply with the specifications contained herein.

## Application, Permit and Inspection Procedures

A property owner, or designated agent, may apply for an approach permit at the Livingston County Road Commission during normal business hours. The Road Commission requires the applicant to provide sufficient site information with the application. This information will vary depending on the type of approach. Please refer to the appropriate section of these specifications for site information requirements.

Fees associated with the application, permit and inspection activities will be indicated on the application form. All fees are due when the application is submitted to the Livingston County Road Commission. The Road Commission may also require security in the form of cash or bank letter of credit to secure the cost of restoring the disturbed portion of highway right-of-way to a safe and acceptable level.

Upon submittal of the application and fees, the applicant will be issued a receipt, and the information provided to the Road Commission will be entered into a database and

scheduled for an Initial Field Inspection.

The receipt issued to the applicant will designate an application number and anticipated completion date of the Initial Field Inspection. The applicant will be responsible for contacting the Road Commission on or after the date indicated on the receipt for a full status of the Initial Field Inspection.

A designated inspector from the Road Commission will conduct the Initial Field Inspection and determine if the approach standards can be met. Due to scheduling limitations, the inspector will generally not be able to meet the applicant on site during the Initial Field Inspection.

If any of the approach standards cannot be met, the applicant will be advised about the deficiencies. All deficiencies must be corrected to the satisfaction of the Road Commission prior to issuance of a Construction Permit. In some instances, plans may be submitted, or previously submitted plans may be revised, to indicate proposed corrections. However, the Road Commission may require the applicant, or the applicant may prefer, to correct the deficiencies under the terms of an Interim Permit. All of the conditions of the Interim Permit must be completed, and verified by an Interim Inspection, prior to issuance of a Construction Permit.

If all of the approach standards can be satisfied, the applicant will be issued a Construction Permit. Any additional costs incurred by the Road Commission, not covered by fees submitted during application, are due at this time. The county or local building department prior to their issuance of a building permit may require a copy of the Construction Permit.

The applicant will be responsible for completing all items of construction set forth in the Construction Permit, prior to the expiration date on the permit. Once completed, the applicant will be responsible for notifying the Road Commission so that a Compliance Inspection can be scheduled. **Failure to notify the Road Commission by the expiration date may result in revocation of the permit and removal (without notice) of any portion of the approach within the highway right-of-way.**

Upon satisfactory completion of the approach, verified by a Compliance Inspection, the Road Commission will issue a Compliance Report to the permit holder indicating compliance. If the approach is determined to be in non-compliance, it will be so noted on the Compliance Report. Items of non-compliance are to be corrected by the permit holder within a reasonable time period, or the permit and approach are subject to revocation and removal, with the permit holder responsible for all costs incurred by the Road Commission.

The county or local building department prior to their issuance of an occupancy permit may require a Compliance Report indicating satisfactory completion.

## RESIDENTIAL DRIVEWAY APPROACHES

### Definition

A driveway approach for the purpose of serving the residents of one single-family dwelling shall be defined as a residential driveway approach. A residential driveway approach may serve up to four single-family dwellings if the applicable local (Township, Village or City) ordinance allows.

An approach that serves more than four single-family dwellings or more than the maximum dwellings allowed by local ordinance for a residential driveway shall be defined as a private road approach, and shall be subject to the requirements described in the *PUBLIC AND PRIVATE ROAD APPROACHES* section.

### Application

A property owner, or designated agent, may apply for a residential driveway approach permit at the Livingston County Road Commission during normal business hours. A survey sketch shall be attached to the application and the location of the property corners and proposed driveway approach must be clearly staked. See the *GENERAL REQUIREMENTS FOR APPROACH PERMITS* section for a detailed description of the application, permit and inspection process.

### Design Features

No portion of a residential driveway approach within the highway right-of-way shall have a grade greater than 10% (1' vertical in 10' horizontal).

A residential driveway approach shall enter perpendicular to the existing roadway.

Typical approach features can be found in *APPENDIX A*. The applicant shall follow these standards unless the Livingston County Road Commission gives approval to do otherwise.

### Drainage Requirements:

- ◆ The Livingston County Road Commission shall determine whether or not a culvert is required and, if required, the diameter and length of the culvert. The applicant shall furnish and install the culvert so determined. The owner or person responsible for the approach shall maintain in perpetuity the culvert in reasonable condition.
- ◆ The minimum length of a culvert may be determined as the width of the approach over the culvert plus the fore slopes from each side of the approach to the ditch bottom. The maximum fore slope is 1 on 3. The Livingston County Road Commission reserves the right to require longer culverts and flatter fore slopes, depending on site-specific conditions.
- ◆ The use of sloped culvert end sections is encouraged. The use of culvert headwalls is prohibited. The enclosure of ditches beyond the end of normal culvert length is prohibited.
- ◆ Culverts shall be installed in line with and on the same grade as the road ditch. Notwithstanding, the Road Commission may require that the applicant re-grade the ditch at his or her expense in order to provide adequate cover over the culvert. The cover, or depth of material over the culvert, should be equal to or greater than the diameter of the culvert.
- ◆ No culvert of less than 12" diameter may be installed.

- ◆ All culverts should be corrugated metal pipes made with steel of the proper gauge corresponding to its diameter, as shown below.

<u>Diameter</u>	<u>Gauge No.</u>
12" - 24"	16
30" - 36"	14
42" - 54"	12
60" - 72"	10

- ◆ If the applicant wishes to install a culvert of material other than that above, approval must be obtained from the Livingston County Road Commission prior to installation.

Location

A residential driveway approach shall be located to provide adequate sight distance for exiting and entering movements (see Sight Distance section). The Road Commission reserves the right to reject a location that is not in the best interest of public safety.

All portions of a residential driveway approach, including the radii, shall be located entirely within the applicant's property lines extended at right angles to the center of the road.

The center of a residential driveway approach should be located at least 25 feet from the applicant's property lines.

The center of a residential driveway approach should be located at least 125 feet from the center of any road approach, regardless of whether the approaches are on the same or opposite side of the road.

The center of a residential driveway approach shall be located at least 125 feet from the nearest track of any railroad-highway grade crossing.

The center of two residential driveway approaches on the same property shall be located at least 100 feet apart, measured parallel to the center of the road.

Access should only be from a residential roadway when a county through highway and residential roadway (public or private) borders a property. Residential developments should be designed, whether the roadways will be public or private, to accommodate driveway access on interior streets. The Livingston County Road Commission reserves the right to deny access on county highways serving through traffic where access is available on residential roads or, in the case of land division by a single proprietor, could have been provided to residential roads.

Number of Approaches

Only one driveway approach is allowed along the frontage of residential property, if the frontage is less than 150 feet. One additional residential driveway approach may be permitted where frontage equals or exceeds 150 feet.

Approaches within Easements

Any residential driveway approach that serves more than one single-family dwelling or serves property without road frontage shall be located within a recorded easement. The easement must be described on the deeds of each affected property and registered with the Livingston County Register of Deeds. Copies of the recorded deeds and survey sketches shall be provided to the Livingston County Road Commission as part of the application and permit process.

A residential driveway approach within an easement will count as one approach on any property with road frontage that includes any portion of the easement.

Residential driveway approaches serving more than one dwelling shall have a minimum width of 20 feet and a maximum width of 30 feet.

Approach Surface

On any roadway, approaches may be paved with asphalt or concrete. Asphalt approaches shall be at least 2 inches in thickness. Concrete approaches shall be at least 5 inches in thickness.

On gravel roadways, residential driveway approaches shall be surfaced with at least 6 inches of processed road gravel. However, when the driveway is paved, the approach shall not be paved closer than 5 feet to the existing road edge.

On paved roadways with road shoulders, residential driveway approaches shall be surfaced with at least 6 inches of processed road gravel. However, when the driveway is paved, the paved approach shall meet the existing roadway pavement and shall follow the same grade as the road shoulder.

On paved roadways with curb and gutter, residential driveway approaches shall be paved.

See APPENDIX A for various approach details.

Sight Distance

Sight distance is the distance along a roadway that an object of specified height is continuously visible to a driver. The following sight distance values, according to the posted or absolute regulatory speed limit, are required for residential driveway approaches.

<u>Speed Limit (mph)</u>	<u>Required Sight Distance (feet)</u>	
	<u>Standard</u>	<u>Minimum Allowable</u>
30 or below	350	260
35	400	300
40	450	335
45	500	375
50	550	410
55	600	450

If a driveway approach is intended to serve only one single-family dwelling, then the values listed as standard represent the minimum requirements for sight distance where existing roadway and site characteristics allow. Where conditions do not allow for the standard, the driveway shall be located in the best location, maximizing sight distance as close to the standard as possible. A permit will not be issued where the minimum allowable sight distance, based on speed conditions, cannot be achieved.

If a driveway approach is intended to serve more than one single-family dwelling, then the values listed as standard represent the minimum requirements for sight distance. A permit will not be issued where the standard sight distance, based on speed conditions, cannot be achieved.

In some instances, the Livingston County Road Commission may reduce the sight distance requirements where conditions limit vehicle speeds in the vicinity of the proposed approach.

On gravel roads that do not have a posted speed limit, residential driveway approaches shall meet the 45-mph requirements for sight distance.

On roadways serving through traffic that have a 25-mph prima facie limit posted, residential driveway approaches shall meet the value listed as standard for sight distance.

Sight distance shall be measured on the edge of the roadway at the center of the approach, using an eye height of 3.5 feet above the road edge and sighting a target 4.25 feet high along the center of each lane on the road. A portion of the target being sighted shall be continuously in view for the required sight distance values. Further, the approach should be located to provide as much of the target in view as possible. The approach should also be located to maximize the view of oncoming traffic for a motorist on the existing county road preparing to turn left at the driveway.

The same sight distance required at the edge of the road shall be continuously provided, along the center of the approach, to a point 15 feet off the edge of the road. The Road Commission may reduce this requirement to a point not less than 10 feet off the edge of the road, depending on site-specific conditions.

A clear vision area, as shown in Figure 1, shall be provided prior to construction and use of any residential driveway approach entering onto a roadway under the jurisdiction of the Livingston County Road Commission. To provide for adequate vision, all obstructions must be removed within the clear vision area. The property owner shall maintain the clear vision area in perpetuity.

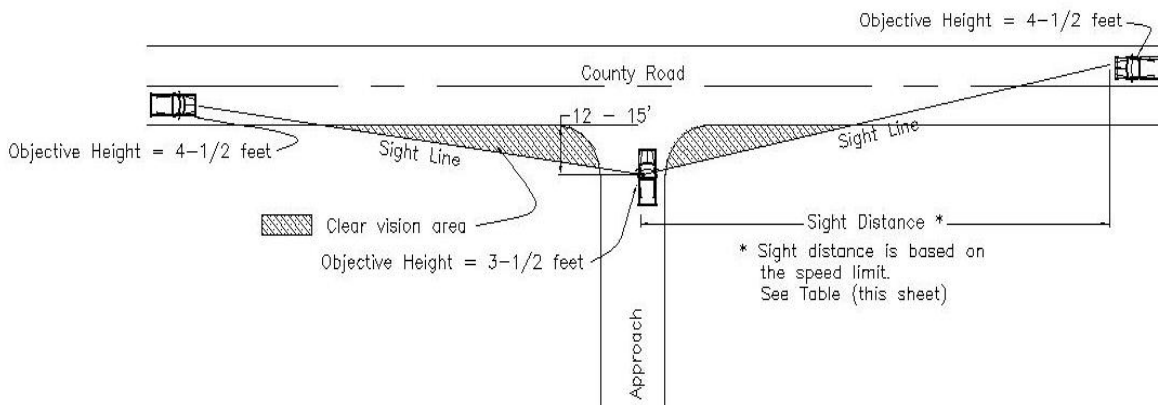

Note: On multilane highways, clear vision shall be provided to the center of each lane in both directions of travel.

Figure 1. Clear vision requirement for residential driveways.

## *FIELD DRIVEWAY APPROACHES*

### Definition

A driveway approach serving cultivated fields, timberland or undeveloped land not used for industrial, commercial or residential purposes shall be defined as a field driveway approach.

### Application

A property owner, or designated agent, may apply for a field driveway approach permit at the Livingston County Road Commission during normal business hours. A survey sketch shall be attached to the application and the location of the property corners and proposed driveway approach must be clearly staked. See the *GENERAL REQUIREMENTS FOR APPROACH PERMITS* section for a detailed description of the application, permit and inspection process.

### Requirements

A proposed field driveway approach shall meet the same specifications as a residential driveway approach.

An existing field driveway approach does not allow a property owner access to a property for residential, commercial or industrial purposes. The property owner must secure the appropriate approach permit for any change in use.

## COMMERCIAL DRIVEWAY APPROACHES

### Definition

A driveway approach providing access to land that is used for industrial, institutional or commercial purposes shall be defined as a commercial driveway approach. Determination by the Livingston County Road Commission, as to whether or not a specific use shall be designated commercial, shall be final and binding.

### Application

A property owner, or designated agent, may apply for a commercial driveway approach permit at the Livingston County Road Commission during normal business hours. Two (2) copies of a site plan shall be attached to the application and the location of the property corners and proposed driveway approach should be clearly staked.

All portions of the application must be completed, including information pertaining to the contractor. A certificate of insurance must be provided with the application or the contractor must have a current copy on file with the Road Commission. The certificate of insurance shall be for comprehensive general liability, on an occurrence basis, in the minimum amount of \$500,000 per person and \$1,000,000 per occurrence. The Livingston County Road Commission shall be listed as an additional named insured on the certificate. The certificate shall be valid until all approach work is completed and the Livingston County Road Commission has acknowledged satisfactory compliance.

See the *GENERAL REQUIREMENTS FOR APPROACH PERMITS* section for a detailed description of the application, permit and inspection process.

### Design Features

No portion of a commercial driveway approach within the highway right-of-way shall have a grade greater than 5% (1' vertical in 20' horizontal).

A commercial driveway approach shall enter perpendicular to the existing roadway, with the entering and exiting radii clearly defined.

The applicant shall provide a right-turn lane and taper and/or passing lane if the Livingston County Road Commission determines that such lanes are required to minimize congestion or hazard on the roadway caused by vehicles entering the applicant's driveway. Factors associated with this determination may include volumes, speeds, vehicle types and roadway alignment.

Typical driveway design features can be found in *APPENDIX A*. The applicant shall follow these standards unless the Livingston County Road Commission gives approval to do otherwise. Design dimensions shown in *APPENDIX A* may be increased by the Road Commission depending on roadway or site characteristics, such as volumes, speeds and vehicle types.

### Drainage Requirements:

- ◆ Existing and proposed elevations shall be indicated on the site plan to clearly define the direction of storm water runoff.
- ◆ Any storm water runoff directed to a county roadway drainage course shall not represent an increase in runoff, shall not exceed a rate of 0.2 cubic feet per second per acre, and shall not exceed a total rate of 8.0 cubic feet per second.
- ◆ Design of detention/retention basins shall be based on a 50-year frequency design storm.
- ◆ Drainage calculations for detention/retention basin storage and discharge orifice size shall be included with the site plan.

- ◆ Existing roadway drainage shall be maintained. Any improvements required to existing roadway drainage facilities to accommodate point discharge or maintain positive drainage shall be the responsibility of the applicant.
- ◆ Temporary and permanent soil erosion control measures shall be indicated on the plan to address discharge into the road right-of-way.
- ◆ The site plan shall clearly show the location, size and length of any culvert to be installed. All culverts shall be of a size adequate to carry the anticipated flow of the ditch based on a 10-year frequency design storm.
- ◆ The minimum length of a culvert may be determined as the width of the approach over the culvert plus the fore slopes from each side of the approach to the ditch bottom. The maximum fore slope is 1 on 3. The Livingston County Road Commission reserves the right to require longer culverts and flatter fore slopes, depending on site-specific conditions.
- ◆ The use of sloped culvert end sections is encouraged. The use of culvert headwalls is prohibited. The enclosure of ditches beyond the end of normal culvert length is prohibited.
- ◆ Culverts shall be installed in line with and on the same grade as the road ditch. Existing road ditch grades shall be shown on the site plan. Proposed ditch grades shall also be shown on the plans when a ditch needs to be re-graded to provide positive flow or to provide adequate cover over the culvert. The cover, or depth of material over the culvert, should be equal to or greater than the diameter of the culvert.
- ◆ The applicant shall furnish and install the culvert approved on the site plan. The owner or person responsible for the approach shall maintain in perpetuity the culvert in reasonable condition.
- ◆ No culvert of less than 12" diameter may be installed.
- ◆ All culverts should be corrugated metal pipes made with steel of the proper gauge corresponding to its diameter, as shown below.

<u>Diameter</u>	<u>Gauge No.</u>
12" - 24"	16
30" - 36"	14
42" - 54"	12
60" - 72"	10

- ◆ If the applicant wishes to install a culvert of material other than that above, approval must be obtained from the Livingston County Road Commission prior to installation.

Location

A commercial driveway approach shall be located to provide adequate sight distance for exiting and entering movements (see Sight Distance section). The Road Commission reserves the right to reject a location that is not in the best interest of public safety.

All portions of a commercial driveway approach, including the radii but excluding deceleration lanes and tapers, shall be located entirely within the applicant's property lines extended at right angles to the center of the road.

The center of a commercial driveway approach should be located at least 50 feet from the applicant's property line.

The center of a commercial driveway approach may be located directly opposite an existing road approach. If offset, the center of the driveway approach should be located at least 250 feet from the center of the existing road approach, regardless of whether the approaches are on the same or opposite side of the road. In the event that site-specific conditions make this requirement unfeasible, the approaches shall be offset the greatest possible distance, but not less than 150 feet. The Livingston County Road Commission reserves the right to increase or decrease these offset requirements, in the interest of public safety, or based on site-specific conditions.

The center of a commercial driveway approach may be located directly opposite an existing commercial driveway approach. If offset, the center of the new driveway approach should be located at least 250 feet from the center of the existing driveway approach, regardless of whether the approaches are on the same or opposite side of the road. In the event that site-specific conditions make this requirement unfeasible, the approaches shall be offset the greatest possible distance. The Livingston County Road Commission reserves the right to increase or decrease these offset requirements, in the interest of public safety, or based on site-specific conditions.

The center of two commercial driveway approaches on the same property should be located at least 250 feet apart, measured parallel to the center of the road. In the event that special circumstances make this requirement unfeasible, the center of the driveways shall be offset the greatest possible distance, but not less than 150 feet.

The center of a commercial driveway approach shall be located at least 250 feet from the nearest track of any railroad-highway grade crossing.

#### Type

A two-way commercial driveway approach shall be the standard driveway approach. Two-way commercial driveways may be either divided or undivided (see *APPENDIX A*). A two-way divided commercial driveway shall have a curbed island separating the entering and exiting movements. The Livingston County Road Commission may require a two-way divided approach under special circumstances in order to maximize sight distance for entering and exiting movements.

A one-way commercial driveway is a special case and may be allowed depending on the site-specific characteristics. A one-way driveway includes separate entering and exiting drives and shall be designed to facilitate the desired turning movements and to discourage prohibited movements. The distance between the center of the ingress drive and the center of the egress drive shall not be less than 100 feet. The installation and maintenance of directional signs and any other traffic control devices shall be the responsibility of the applicant and shall be shown on the site plan.

#### Number of Driveways

On each roadway, one approach is allowed for each commercial property where frontage is less than 350 feet. One additional approach may be permitted where frontage equals or exceeds 350 feet, or at the discretion of the Livingston County Road Commission, for site-specific reasons.

#### Joint Driveway

When both property owners abutting a common property line agree, they may construct a joint commercial driveway approach that shall have the same design features as a two-way commercial driveway approach. A joint commercial driveway approach shall be located within a recorded easement that is described on the deeds of each affected property and registered with the Livingston County Register of Deeds. Copies of the deeds and survey sketches shall be provided to the Livingston County Road Commission as part of the application and permit process.

Approach Surface

A commercial driveway approach shall be surfaced from the edge of the traveled way to the right-of-way line with a material that is equal to or better than the surface of the roadway which it joins. The Livingston County Road Commission shall determine whether or not a material is equal to or better than the surface of the roadway.

Gravel approaches are allowed only on gravel roadways and shall be constructed with at least 7 inches of processed road gravel on 6 inches of Class-II sand.

Asphalt approaches shall be constructed with at least 3 inches of asphalt (2 lifts) on 7 inches of processed road gravel and 6 inches of Class-II sand.

Concrete approaches shall be constructed with at least 6 inches of concrete on 6 inches of Class-II sand.

The Road Commission may require a special pavement design under certain conditions including but not limited to poor soil, industrial or heavy truck use, or all-weather route.

On paved roadways with road shoulders, paved approaches shall follow the same grade as the road shoulder.

On gravel roadways, paved approaches shall not be paved closer than 5 feet to the existing road edge.

Any approach on a roadway designated as all weather shall be constructed with at least 2 inches of asphalt surface on 5 inches of asphalt base, 4 inches of processed road gravel and 6 inches of Class-II sand.

Any curb placed within the highway right-of-way shall be concrete. No curb shall be placed within the limits of a road shoulder.

Parking

The applicant will be required to prevent parking in the highway right-of-way. The Road Commission will not issue permits for commercial properties that encourage the stopping or standing of vehicles in the right-of-way or the backing of vehicles from the highway onto the sites.

Sight Distance

Sight distance is the distance along a roadway that an object of specified height is continuously visible to a driver. The following sight distance values, according to the posted or absolute regulatory speed limit, are required for commercial driveway approaches.

<u>Speed Limit (mph)</u>	<u>Required Sight Distance (feet)</u>	
	<u>Standard</u>	<u>Minimum Allowable</u>
30 or below	500	350
35	575	400
40	650	450
45	725	500
50	800	550
55	875	600

The values listed as standard represent the minimum requirements for sight distance where existing roadway and site characteristics allow. Where conditions do not allow for the standard, the driveway shall be located in the best location, maximizing sight distance as close to the standard as possible. A permit will not be issued where the minimum allowable sight distance, based on speed conditions, cannot be achieved. In some instances, the Livingston County Road Commission may reduce the sight distance requirements where conditions limit vehicle speeds in the vicinity of the proposed approach.

On gravel roads that do not have a posted speed limit, commercial driveway approaches shall meet the 45-mph requirements for sight distance.

On roadways serving through traffic that have a 25-mph prima facie limit posted, commercial driveway approaches shall meet the value listed as standard for sight distance.

Sight distance shall be measured on the edge of the roadway at the center of the approach, using an eye height of 3.5 feet above the road edge and sighting a target 4.25 feet high along the center of each lane on the road. A portion of the target being sighted shall be continuously in view for the required sight distance values. Further, the approach should be located to provide as much of the target in view as possible. The approach should also be located to maximize the view of oncoming traffic for a motorist on the existing county road preparing to turn left at the driveway.

The same sight distance required at the edge of the road shall be continuously provided, along the center of the approach, to a point 15 feet off the edge of the road. The Road Commission may reduce this requirement to a point not less than 10 feet off the edge of the road, depending on site-specific conditions.

A clear vision area, as shown in Figure 2, shall be provided prior to construction and use of any commercial driveway approach entering onto a roadway under the jurisdiction of the Livingston County Road Commission. To provide for adequate vision, all obstructions must be removed within the clear vision area. The property owner shall maintain the clear vision area in perpetuity.

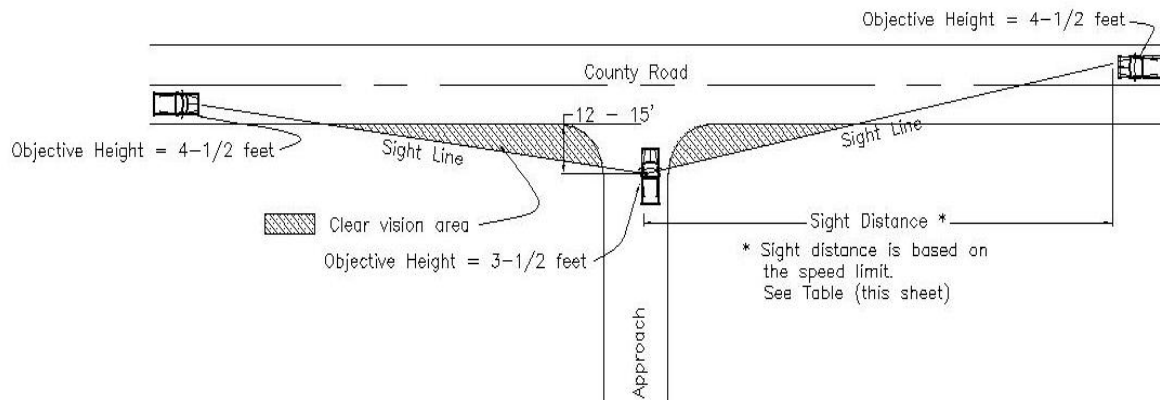

Note: On multilane highways, clear vision shall be provided to the center of each lane in both directions of travel.

Figure 2. Clear vision requirement for commercial driveways.

## PUBLIC AND PRIVATE ROAD APPROACHES

### Definition

A public road approach shall be defined as an approach serving a roadway that is dedicated to the use of the public.

A private road approach shall be defined as an approach serving a roadway that is dedicated to the use of the property owner(s).

### Application

A property owner, or designated agent, may apply for a private road approach permit at the Livingston County Road Commission during normal business hours. Two (2) copies of a site plan shall be attached to the application and the location of the property corners and proposed road approach should be clearly staked.

All portions of the private road approach application must be completed, including information pertaining to the contractor. A certificate of insurance must be provided with the application or the contractor must have a current copy on file with the Road Commission. The certificate of insurance shall be for comprehensive general liability, on an occurrence basis, in the minimum amount of \$500,000 per person and \$1,000,000 per occurrence. The Livingston County Road Commission shall be listed as an additional named insured on the certificate. The certificate shall be valid until all approach work is completed and the Livingston County Road Commission has acknowledged satisfactory compliance.

See the *GENERAL REQUIREMENTS FOR APPROACH PERMITS* section for a detailed description of the application, permit and inspection process.

Public road approaches are reviewed as part of a development process. Plans should be submitted in accordance with Specifications for Plat Development, but will be required to meet all of the specifications outlined in this section.

### Design Features

Included on the site plan shall be the name(s) of proposed public or private road(s).

No portion of a public or private road approach within the highway right-of-way shall have a grade greater than 5% (1' vertical in 20' horizontal).

A public or private road approach shall enter perpendicular to the existing roadway.

When a public road approach enters off an existing public road cul-de-sac, the outer paved portions of the cul-de-sac shall be removed, the drainage facility relocated, and the disturbed area restored to constitute a continuously uniform roadbed. All costs associated with this work shall be the responsibility of the applicant.

When a private road approach enters off an existing public road cul-de-sac, special provisions and/or clear vision areas may be required within the private development to ensure adequate sight distance at residential driveways on the public road.

The applicant shall provide a right-turn lane and taper and/or passing lane if the Livingston County Road Commission determines that such lanes are required to minimize congestion or hazard on the roadway caused by vehicles entering the applicant's public or private road approach. Factors associated with this determination may include volumes, speeds, vehicle types and roadway alignment.

Typical design features for public and private road approaches can be found in *APPENDIX A*. The applicant shall follow these standards unless approval to do otherwise is given by the Livingston County Road Commission. Design dimensions shown in *APPENDIX A* may be increased by the Road Commission depending on roadway or site characteristics, such as volumes, speeds and vehicle types.

Other standards for public roads are found in the Specifications for Plat Development.

Drainage Requirements:

- ◆ Existing and proposed elevations shall be indicated on the site plan to clearly define the direction of storm water runoff.
- ◆ Any storm water runoff directed to a county roadway drainage course shall not represent an increase in runoff, shall not exceed a rate of 0.2 cubic feet per second per acre, and shall not exceed a total rate of 8.0 cubic feet per second.
- ◆ Design of detention/retention basins shall be based on a 50-year frequency design storm.
- ◆ Drainage calculations for detention/retention basin storage and discharge orifice size shall be included with the site plan.
- ◆ Existing roadway drainage shall be maintained. Any improvements required to existing roadway drainage facilities to accommodate point discharge or maintain positive drainage shall be the responsibility of the applicant.
- ◆ Temporary and permanent soil erosion control measures shall be indicated on the plan to address discharge into the road right-of-way.
- ◆ The site plan shall clearly show the location, size and length of any culvert to be installed. All culverts shall be of a size adequate to carry the anticipated flow of the ditch based on a 10-year frequency design storm.
- ◆ The minimum length of a culvert may be determined as the width of the approach over the culvert plus the fore slopes from each side of the approach to the ditch bottom. The maximum fore slope is 1 on 3. The Livingston County Road Commission reserves the right to require longer culverts and flatter fore slopes, depending on site-specific conditions.
- ◆ The use of sloped culvert end sections is encouraged. The use of culvert headwalls is prohibited. The enclosure of ditches beyond the end of normal culvert length is prohibited.
- ◆ Culverts shall be installed in line with and on the same grade as the road ditch. Existing road ditch grades shall be shown on the site plan. Proposed ditch grades shall also be shown on the plans when a ditch needs to be re-graded to provide positive flow or to provide adequate cover over the culvert. The cover, or depth of material over the culvert, should be equal to or greater than the diameter of the culvert.
- ◆ The applicant shall furnish and install the culvert approved on the site plan. The owner or person responsible for the approach shall maintain in perpetuity the culvert in reasonable condition.
- ◆ No culvert of less than 12" diameter may be installed.

- ◆ All culverts should be corrugated metal pipes made with steel of the proper gauge corresponding to its diameter, as shown below.

<u>Diameter</u>	<u>Gauge No.</u>
12" - 24"	16
30" - 36"	14
42" - 54"	12
60" - 72"	10

- ◆ If the applicant wishes to install a culvert of material other than that above, approval must be obtained from the Livingston County Road Commission prior to installation.

Location

A private or public road approach shall be located to provide adequate sight distance for exiting and entering movements (see Sight Distance section). The Road Commission reserves the right to reject a location that is not in the best interest of public safety.

The center of a public or private road approach may be located directly opposite an existing road approach. If offset, the center of the new approach should be located at least 660 feet from the center of the existing road approach, regardless of whether the approaches are on the same or opposite side of the road. In the event that site-specific conditions make this requirement unfeasible, the approaches shall be offset the greatest possible distance, but not less than 250 feet. The Livingston County Road Commission reserves the right to increase or decrease these offset requirements, in the interest of public safety, or based on site-specific conditions.

The center of two public or private road approaches on the same property shall be located at least 660 feet apart.

The center of a public or private road approach may be located directly opposite an existing commercial driveway approach. If offset, the center of the road approach should be located at least 250 feet from the center of the existing driveway approach, regardless of whether the approaches are on the same or opposite side of the road. In the event that site-specific conditions make this requirement unfeasible, the approaches shall be offset the greatest possible distance, but not less than 150 feet. The Livingston County Road Commission reserves the right to increase or decrease these offset requirements, in the interest of public safety, or based on site-specific conditions.

The center of a public or private road approach should be located at least 125 feet from the center of any existing residential driveway approach, regardless of whether the approaches are on the same or opposite side of the road.

The center of a public or private road approach shall be located at least 250 feet from the nearest track of any railroad-highway grade crossing.

Type

A two-way approach shall be the standard road approach for public or private roads. Two-way road approaches may be either divided or undivided (see APPENDIX A). A two-way divided approach shall have a curbed island separating the entering and exiting movements. The Livingston County Road Commission may require a two-way divided approach under special circumstances in order to maximize sight distance for entering and exiting movements.

Approach Surface

All road approaches shall be surfaced from the edge of the traveled way to the right-of-way line with a material that is equal to or better than the surface of the roadway which it joins. The Livingston County Road Commission shall determine whether or not a material is equal to or better than the surface of the roadway.

A gravel private road approach is allowed only on a gravel roadway and shall be constructed with at least 7 inches of processed road gravel on 6 inches of Class-II sand.

An asphalt road approach shall be constructed with at least 3 inches of asphalt (2 lifts) on 7 inches of processed road gravel and 6 inches of Class-II sand.

A concrete road approach shall be constructed with at least 6 inches of concrete on 6 inches of Class-II sand.

The Road Commission may require a special pavement design under certain conditions including but not limited to poor soil, industrial or heavy truck use, or all-weather route.

On a paved roadway with road shoulders, a paved road approach shall follow the same grade as the road shoulder.

On a gravel roadway, a paved road approach shall not be paved closer than 5 feet to the existing road edge.

Any road approach on a roadway designated as all weather shall be constructed with at least 2 inches of asphalt surface on 5 inches of asphalt base, 4 inches of processed road gravel and 6 inches of Class-II sand.

Any curb placed within the highway right-of-way shall be concrete. No curb shall be placed within the limits of a road shoulder.

Construction standards for public roads are contained in Specifications for Plat Development.

Sight Distance

Sight distance is the distance along a roadway that an object of specified height is continuously visible to a driver. The following sight distance values, according to the posted or absolute regulatory speed limit, are required for public and private road approaches.

<u>Speed Limit (mph)</u>	<u>Required Sight Distance (feet)</u>	
	<u>Standard</u>	<u>Minimum Allowable</u>
30 or below	500	350
35	575	400
40	650	450
45	725	500
50	800	550
55	875	600

Those values listed as standard represent the minimum requirements for sight distance where existing roadway and site characteristics allow. Where conditions do not allow for the standard, the road approach shall be located in the best location, maximizing sight distance as close to the standard as possible. A permit will not be issued where the minimum allowable sight distance, based on speed conditions, cannot be achieved. In some instances, the Livingston County Road Commission may reduce the sight distance requirements for site-specific conditions that limit vehicle speeds in the vicinity of the proposed approach.

On gravel roads that do not have a posted speed limit, public and private road approaches

shall meet the 45-mph requirements for sight distance.

On roadways serving through traffic that have a 25-mph prima facie limit posted, public and private road approaches shall meet the value listed as standard for sight distance.

Sight distance shall be measured on the edge of the roadway at the center of the approach, using an eye height of 3.5 feet above the road edge and sighting a target 4.25 feet high along the center of each lane on the road. A portion of the target being sighted shall be continuously in view for the required sight distance values. Further, the approach should be located to provide as much of the target in view as possible. The approach should also be located to maximize the view of oncoming traffic for a motorist on the existing county road preparing to turn left at the road approach.

The same sight distance required at the edge of the road shall be continuously provided, along the center of the approach, to a point 15 feet off the edge of the road. The Road Commission may reduce this requirement to a point not less than 10 feet off the edge of the road, depending on site-specific conditions.

A clear vision area, as shown in Figure 3, shall be provided prior to construction and use of any public or private road approach entering onto a roadway under the jurisdiction of the Livingston County Road Commission. To provide for adequate vision, all obstructions must be removed within the clear vision area. The clear vision area shall be maintained in perpetuity by the property owner(s).

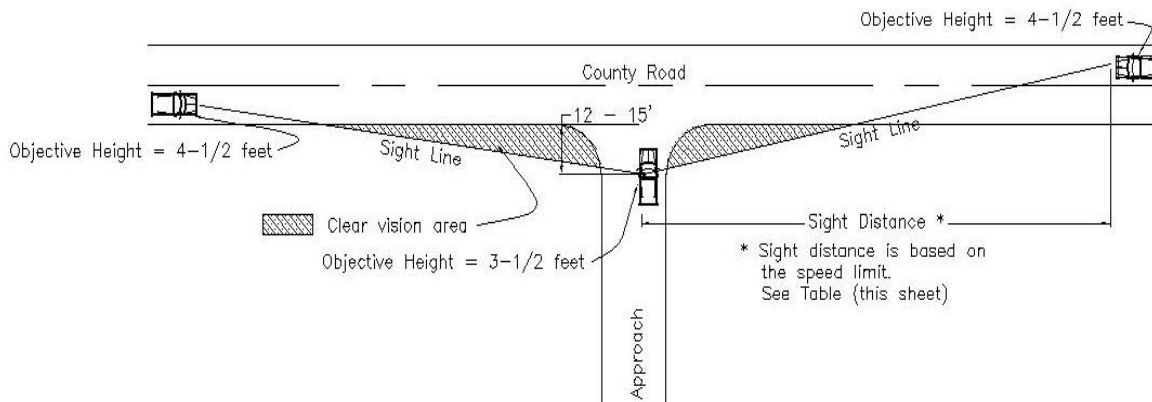

Note: On multilane highways, clear vision shall be provided to the center of each lane in both directions of travel.

Figure 3. Clear vision requirement for public and private road approaches.

## RECREATIONAL (CELEBRATIONS AND FESTIVALS) DRIVEWAY APPROACHES

### General

A driveway approach permit for the temporary access of a roadway under the jurisdiction of the Livingston County Road Commission for the purpose of a celebration or festival may be issued by the Road Commission only to the governing body of a city, village or township. This requirement shall hold true whether the applicant wishes to utilize an existing driveway approach or construct a temporary approach.

### Advance Notice

Application for the driveway approach permit must be made at least 30 days prior to the event, to provide the Road Commission ample time to review the event with the governing city, village or township.

### Location

The applicant shall provide, at the time of request, a sketch showing the property layout and location of the desired access point(s).

### Design Features

The Road Commission on an individual basis, due to the variable nature of the event will review all driveway approach design features.

### Insurance Requirements

The local governing body shall provide the Road Commission with a certificate of insurance for comprehensive general liability, on an occurrence basis, in the minimum amount of \$500,000 per person and \$1,000,000 per occurrence. The Livingston County Road Commission shall be listed as an additional named insured on the certificate.

## ROAD CLOSURES FOR PARADES, CELEBRATIONS AND FESTIVALS

### General

A permit granting permission for the temporary closure of a road for a reasonable length of time for a parade, celebration, festival or any other purpose may be issued by the Road Commission only to the governing body of a city, village or township.

### Advance Notice

Application for the permit must be made at least 30 days prior to the event, to provide the Road Commission ample time to review the event with the governing city, village or township.

### Application Provisions

The application, supplied by the Road Commission, shall state the nature of the activity, the proposed dates and times to close and reopen the roadway to traffic and such other information that the Road Commission may require. The Road Commission shall approve the reasonable period of time. A copy of a resolution shall also accompany the application from the city, village or township requesting permission for the closure or partial closure.

A permit shall be issued subject to the following conditions:

- ◆ The closure or partial closure and the use of a detour route shall not unduly interfere with the safe and free movement of traffic.
- ◆ A suitable alternate location is not available for the parade, celebration or festival that is more acceptable for traffic safety and causes less interruption of traffic.
- ◆ A closure or partial closure normally shall be allowed only during daylight hours. When temporary nighttime closure is permitted, points of potential hazard, barricades and warning signs shall be lighted at the applicant's expense. The lighting shall be in accordance with requirements and specifications of the Road Commission.

### Traffic Control Devices

Traffic control devices installed in conjunction with the closure or partial closure and the detour route shall conform to the provisions of the Michigan Manual of Uniform Traffic Control Devices.

Required traffic control devices may be furnished and installed either by the local governing body or by the Road Commission. Costs arising from the installation, maintenance and removal of such devices shall be borne by the applicant.

The local governing body shall provide necessary police and fire supervision.

### Insurance Requirements

The local governing body shall provide the Road Commission with a certificate of insurance for comprehensive general liability, on an occurrence basis, in the minimum amount of \$500,000 per person and \$1,000,000 per occurrence. The Livingston County Road Commission shall be listed as an additional named insured on the certificate.

## *BANNER PERMITS*

### General

A permit for the installation of banners to be placed within or over a road right-of-way under the jurisdiction of the Road Commission may be issued only to the governing body of a city, village or township.

### Advance Notice

Application for the permit must be made at least 30 days prior to the anticipated placement of the banner, to provide the Road Commission ample time to review the requirements with the governing city, village or township.

### Application Provisions

An application for a permit, provided by the Road Commission, for the installation of a banner shall include the following as a minimum:

- ◆ Activity in connection with which the banners are to be placed.
- ◆ Location of the proposed installation including distance to overhead traffic control devices.
- ◆ Description of the banner, including any legend or symbol thereon.
- ◆ Height of an overhead banner at its lowest point above the pavement.
- ◆ Date on which the banner will be installed and removed. The period shall not exceed a time period specified by the Road Commission.

Also, a copy of a resolution shall accompany the application from the city, village or township requesting permission for a banner.

### Design and Placement

The design, method of installation and location of banners shall not endanger persons using the roadway or unduly interfere with the free movement of traffic.

An overhead banner shall have a minimum bottom height of 18 feet above the roadway, shall not be placed closer than 100 feet on either side of traffic signals, and shall not be placed so as to obstruct a clear view of traffic signals or other traffic control devices.

### Contents of Banners

A banner shall not have displayed thereon any legend or symbol that may be construed to advertise, promote the sale of or publicize any merchandise or commodity, or to be political in nature.

A banner shall not have displayed thereon any legend or symbol that is or purports to be an imitation of or resembles, or which may be mistaken for, a traffic control device, or which attempts to direct the movement of traffic.

Decorations shall not include flashing lights or any other type of lights that may be distracting to motorists.

Insurance Requirements

The local governing body shall provide the Road Commission with a certificate of insurance for comprehensive general liability, on an occurrence basis, in the minimum amount of \$500,000 per person and \$1,000,000 per occurrence. The Livingston County Road Commission shall be listed as an additional named insured on the certificate.

Cancellation of Permits

A permit for the installation of a banner may be cancelled by the Road Commission if the installation becomes dangerous to motorists or unduly interferes with the free movement of traffic.

## VARIANCE IN STANDARDS

The Board may allow a variance only in cases involving practical difficulties or unnecessary hardship, when the record to the Board supports all of the following affirmative findings:

- 1) That the alleged hardship or practical difficulties, or both, are exceptional and peculiar to the property.
- 2) That the alleged hardship or practical difficulties, or both, which would result from a failure to grant the variance, include substantially more than inconvenience or inability to attain a higher financial return, or both.
- 3) That allowing the variance will result in substantial justice being done, considering the public benefits and the individual hardships that will be suffered by a failure of the Board to grant a variance.
- 4) That the conditions and circumstances, which are the bases of the variance request, shall not be self-imposed.

If a variance has been granted, and the construction authorized with the variance has not commenced within one year from the date of its approval, the grant of the variance shall be automatically withdrawn.

## VALIDITY

Each section, subsection, provision, requirement, regulation or restriction established by these rules for driveway permits or any amendments or additions thereto, is hereby declared to be independent, and the holding of any part to be unconstitutional, invalid or ineffective for any cause shall not affect nor render invalid the resolution or amendments or additions thereto as a whole or any other part thereof, except as to the particular part so declared to be invalid.

Adopted by the Board November 12, 1998  
Effective January 1, 1999

LIVINGSTON COUNTY BOARD OF ROAD COMMISSIONERS

J. Gordon Topping  
Richard I. Slayton  
John T. Dunleavy

APPENDIX A - TYPICAL DESIGN STANDARDS

<u>Standard</u>	<u>Page</u>
Cross-Section of Residential Driveway Approach on Gravel County Road .....	A.2
Cross-Section of Residential Driveway Approach of Paved, Uncurbed County Road ..	A.3
Cross-Section of Residential Driveway Approach of Paved, Curbed County Road ....	A.4
Residential Driveway Approach on Uncurbed County Road .....	A.5
Residential Driveway Approach on Curbed County Road .....	A.6
Commercial Driveway Approach .....	A.7
Divided Commercial Driveway Approach .....	A.8
One-Way Commercial Driveway Approach .....	A.9
Gravel Private Road Approach on Gravel County Road .....	A.10
Paved Road Approach on Gravel County Road .....	A.11
Paved Road Approach on Paved County Road .....	A.12
Divided Paved Road Approach on Paved County Road .....	A.13
Left-Turn Passing Lane .....	A.14
Left-Turn Passing Lane Warrant .....	A.15

# Cross-Section of Residential Driveway Approach on Gravel County Road

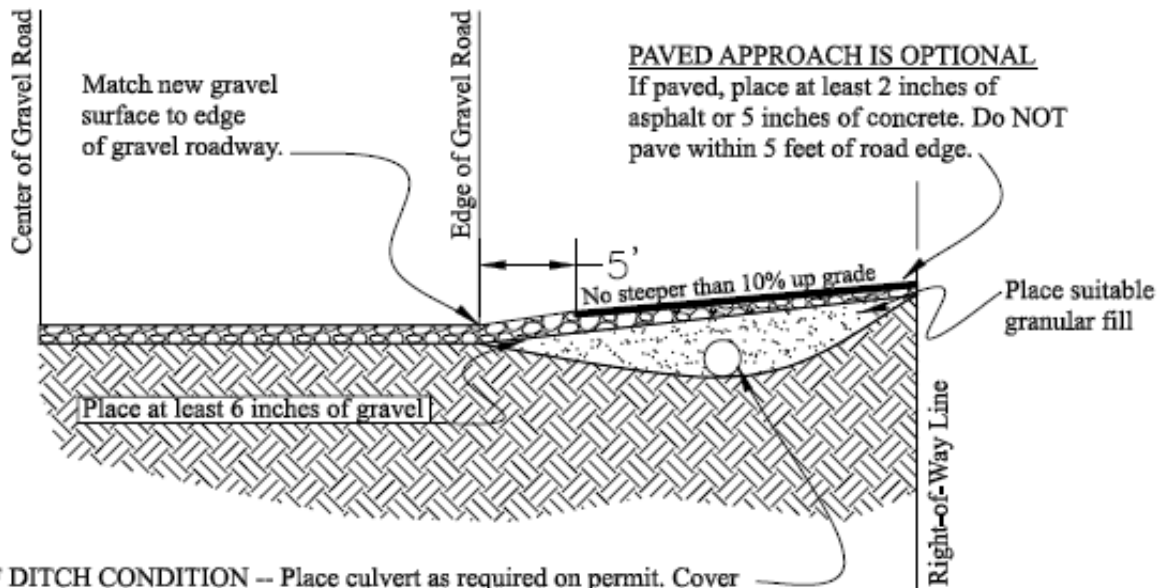

IF DITCH CONDITION -- Place culvert as required on permit. Cover (depth of material over culvert) should be equal to or greater than diameter of culvert. This is for culverts less than 24 inches in diameter.

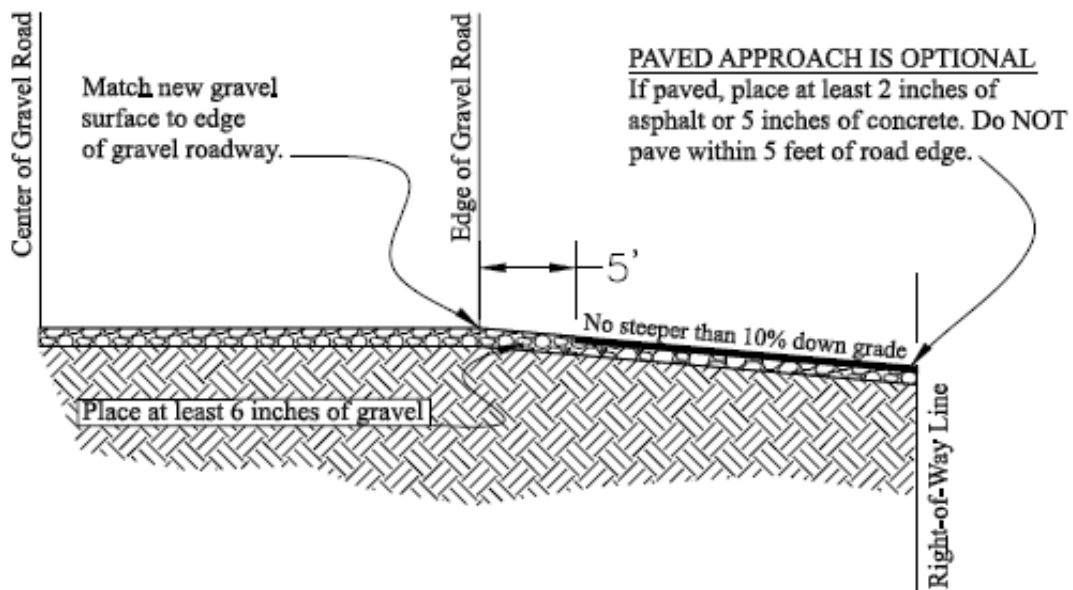

# Cross-Section of Residential Driveway Approach on Paved, Uncurbed County Road

Match new surface to edge of paved road and follow same grade as road shoulder.

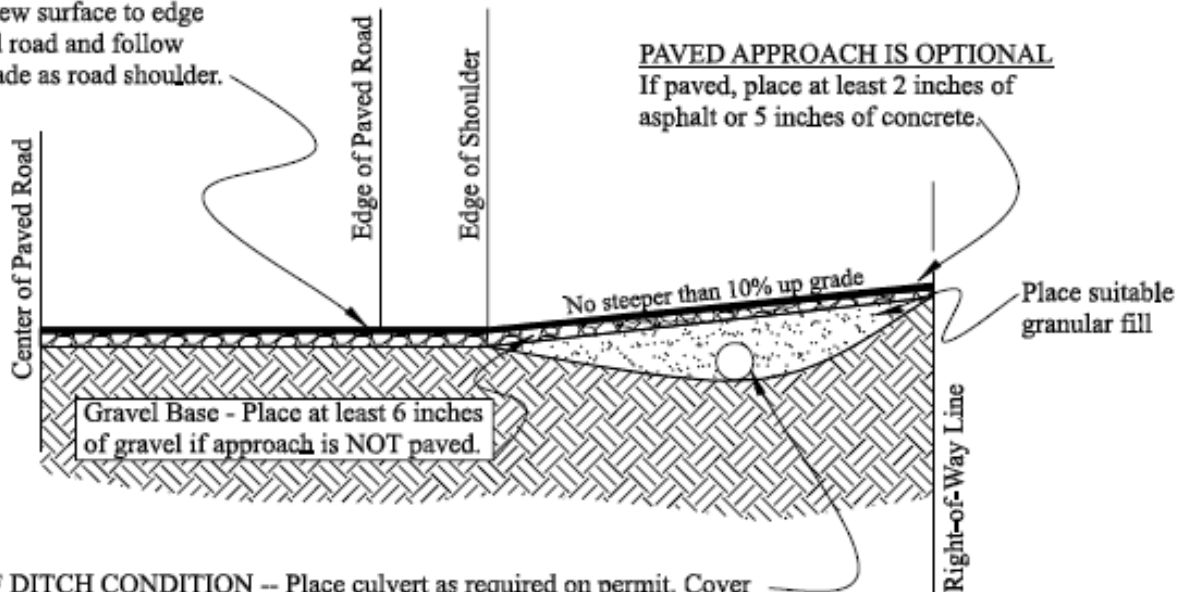

IF DITCH CONDITION -- Place culvert as required on permit. Cover (depth of material over culvert) should be equal to or greater than diameter of culvert. This is for culverts less than 24 inches in diameter.

Match new surface to edge of paved road and follow same grade as road shoulder.

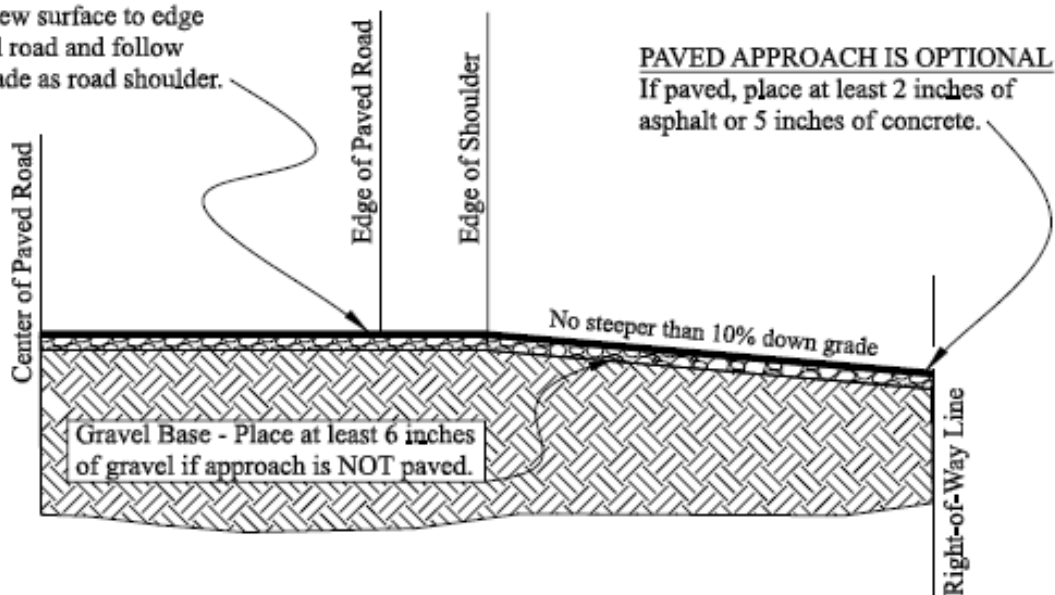

# Cross-Section of Residential Driveway Approach on Paved, Curbed County Road

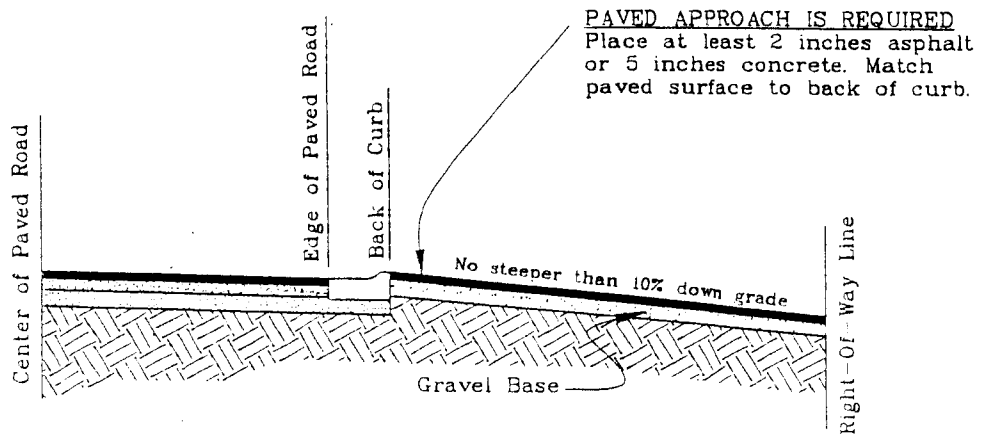
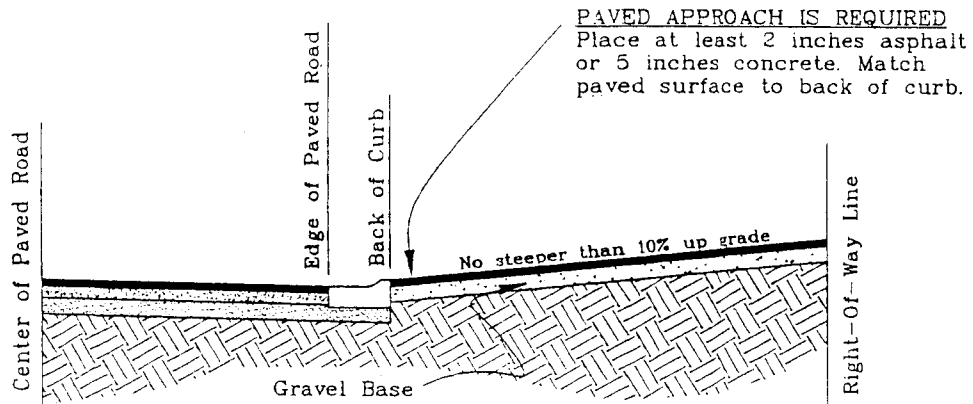

# Residential Driveway Approach on Uncurbed County Road

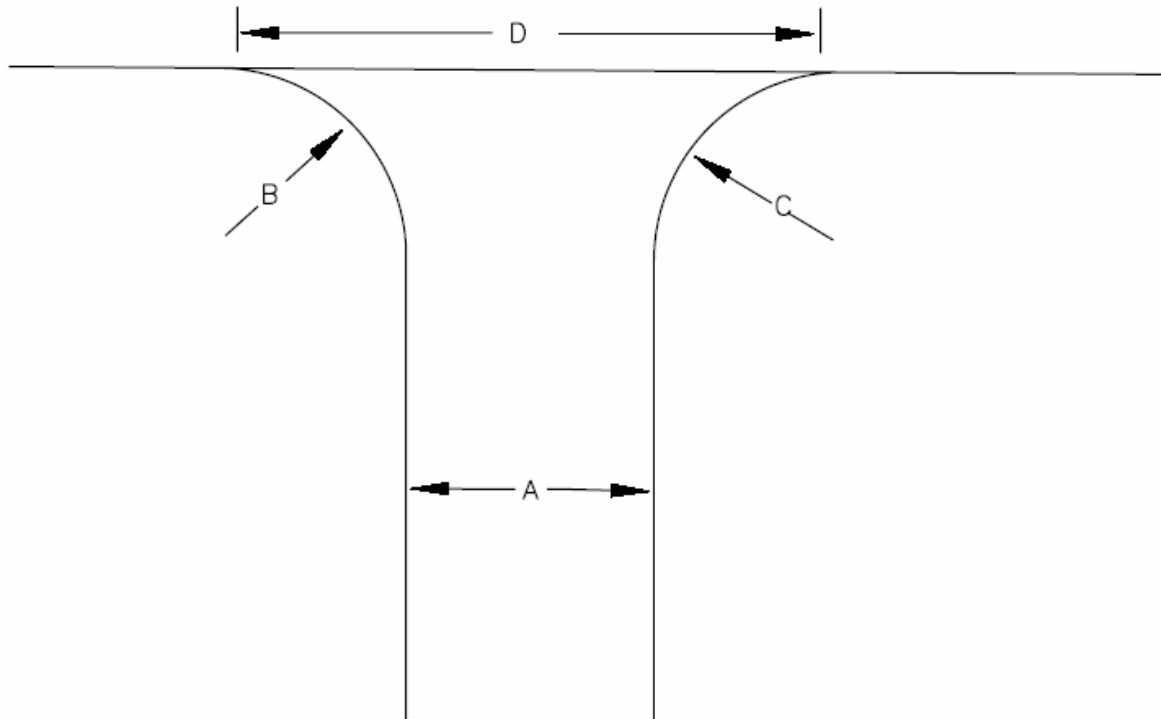

	Design Feature	Standard	Range
A	Driveway Width	12'	10' to 30'
B	Entering Radius	10'	5' to 15'
C	Existing Radius	10'	5' to 15'
D	Total Opening (A+B+C)	32'	20' to 60'

The Standard shall be used unless engineering judgement deters that another dimension within the range is more suitable for a particular site or special condition and is approved by Livingston County Road Commission.

# Residential Driveway Approach on Curbed County Road

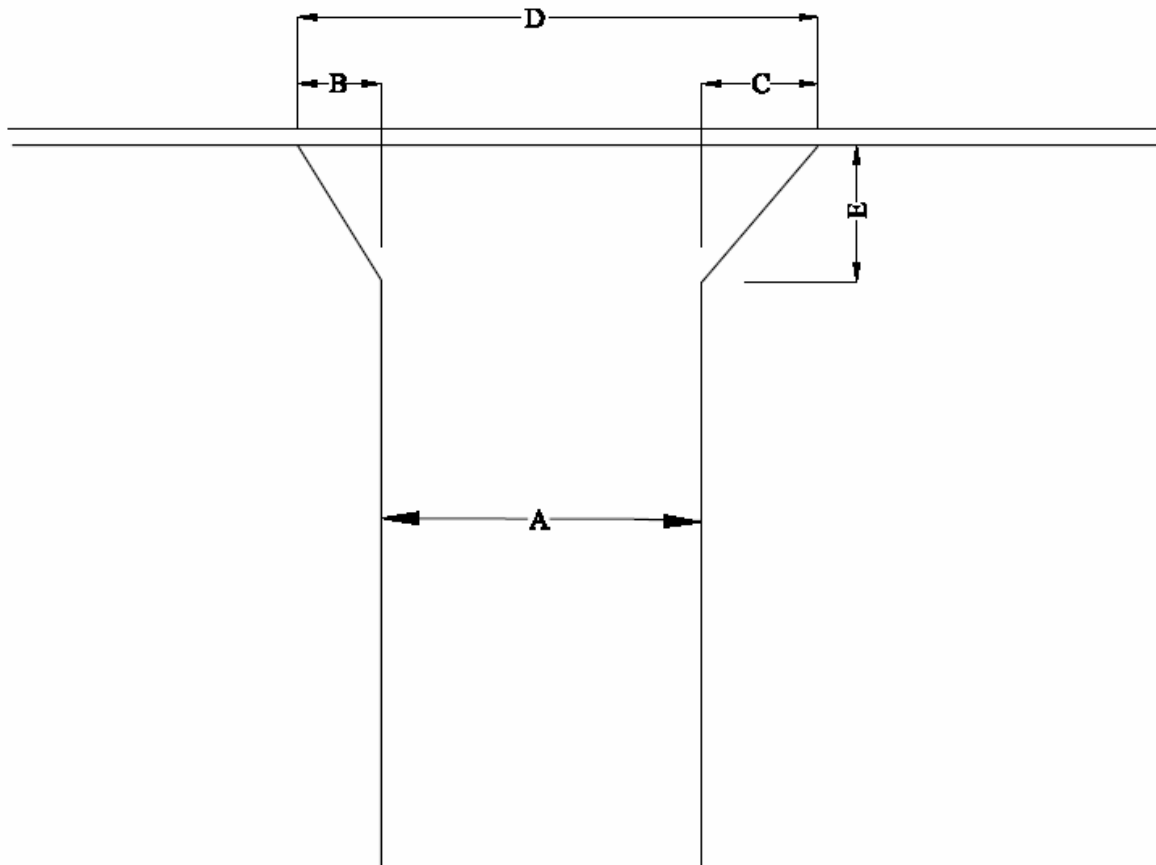

	Design Feature	Standard	Range
A	Driveway Width	12'	10' to 30'
B	Entering Taper Width	6'	4' to 15'
C	Existing Taper Width	6'	4' to 15'
D	Total Opening (A+B+C)	24'	18' to 60'
E	Taper Depth	10'	10' to 20'

The Standard shall be used unless engineering judgement deems that another dimension within the range is more suitable for a particular site or special condition and is approved by Livingston County Road Commission.

# Commerical Driveway Approach

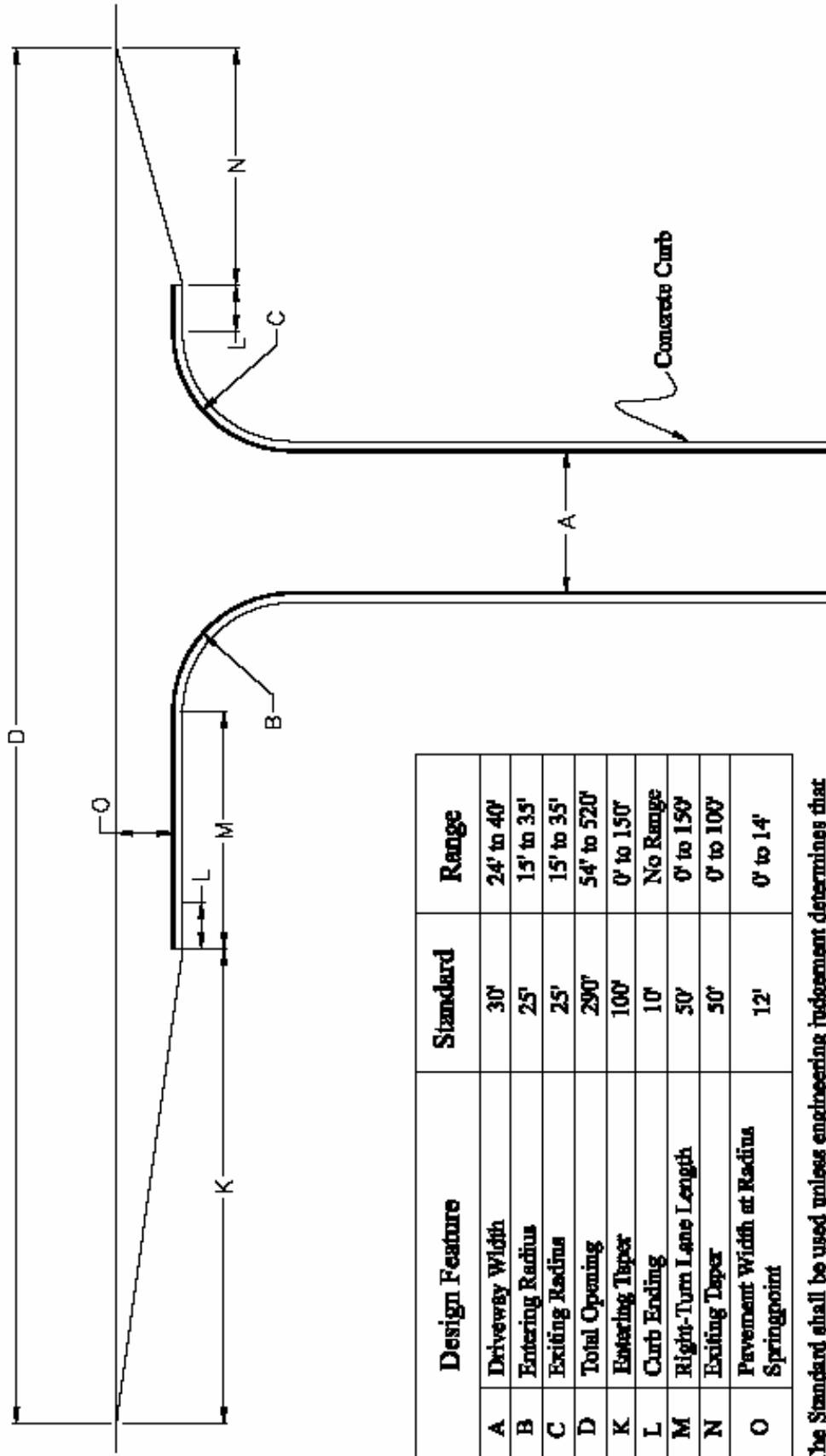

Design Feature	Standard	Range
A	30'	24' to 40'
B	25'	15' to 35'
C	25'	15' to 35'
D	290'	54' to 520'
K	100'	0' to 150'
L	10'	No Range
M	50'	0' to 150'
N	50'	0' to 100'
O	12'	0' to 14'

The Standard shall be used unless engineering judgement determines that another dimension within the range is more suitable for a particular site or special condition and is approved by Livingston County Road Commission.

**NOTE:** Concrete curb is optional on approaches to uncurbed county roadways.

# Divided Commercial Driveway Approach

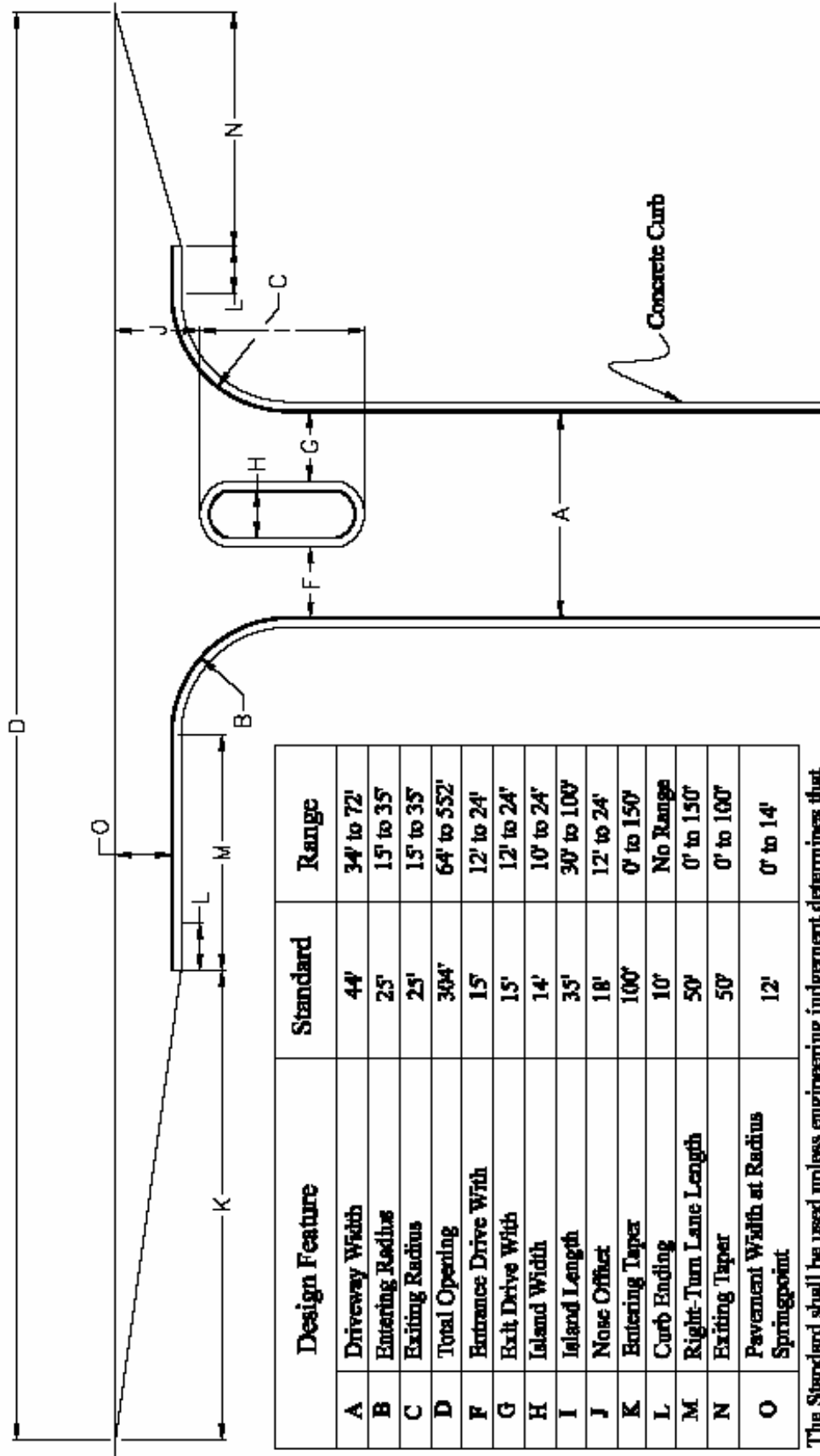

Design Feature	Standard	Range
A	44'	34' to 72'
B	25'	15' to 35'
C	25'	15' to 35'
D	304'	64' to 552'
F	15'	12' to 24'
G	15'	12' to 24'
H	14'	10' to 24'
I	35'	30' to 100'
J	18'	12' to 24'
K	100'	0' to 150'
L	10'	No Range
M	50'	0' to 150'
N	50'	0' to 100'
O	12'	0' to 14'

The Standard shall be used unless engineering judgement determines that another dimension within the range is more suitable for a particular site or special condition and is approved by Livingston County Road Commission.

NOTE: Concrete curb is optional on approaches to uncurbed county roadways.

# One-way Commerical Driveway Approach

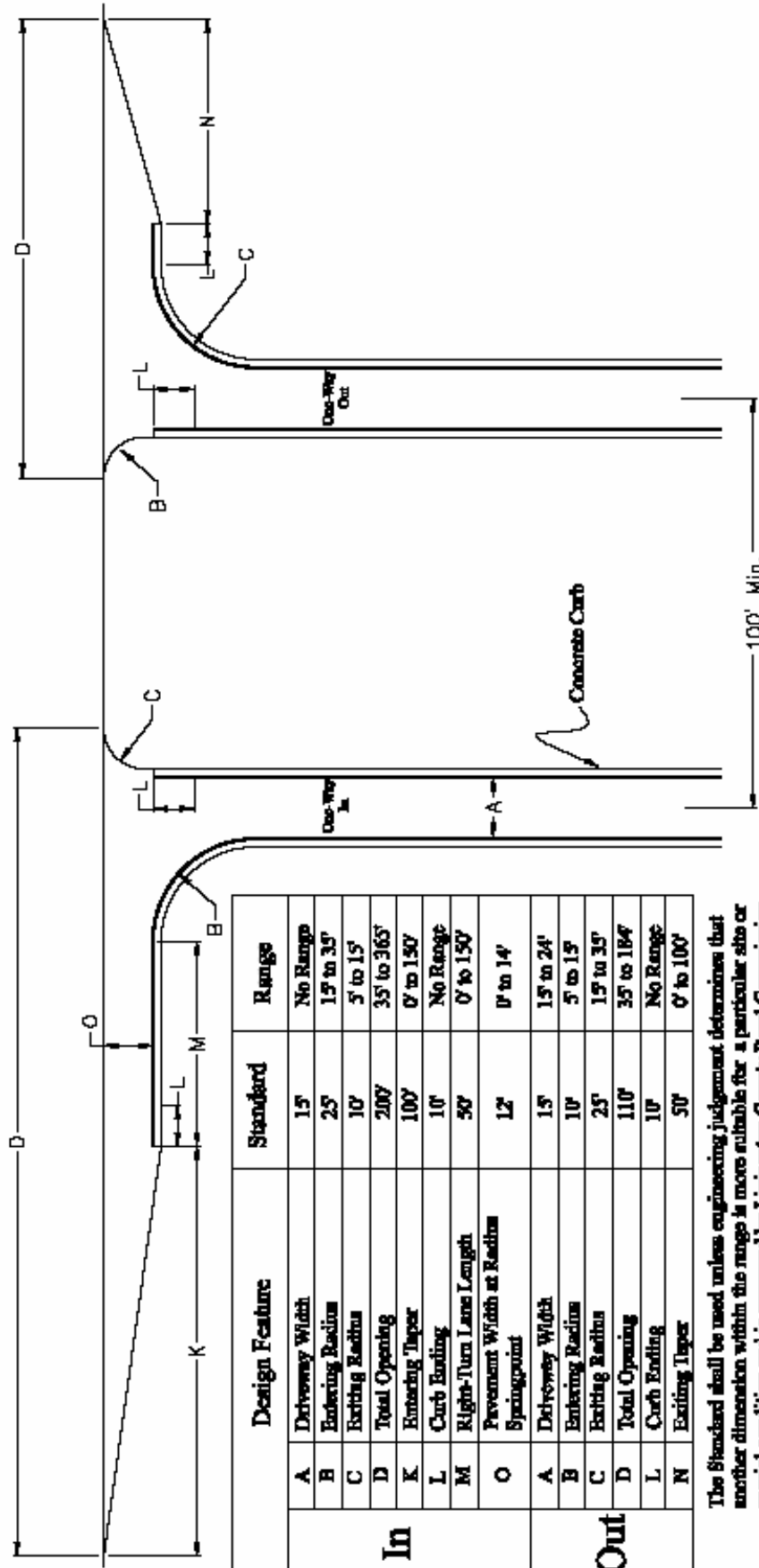

Design Feature	Standard	Range
A Driveway Width	15'	No Range
B Entering Radius	25'	15' to 35'
C Exiting Radius	10'	5' to 15'
D Total Opening	200'	35' to 365'
K Entering Taper	100'	0' to 150'
L Curb Ending	10'	No Range
M Right-Turn Lane Length	50'	0' to 150'
O Pavement Width at Radius	12'	0' to 14'
A Driveway Width	15'	15' to 24'
B Entering Radius	10'	5' to 15'
C Exiting Radius	25'	15' to 35'
D Total Opening	110'	35' to 184'
L Curb Ending	10'	No Range
N Exiting Taper	50'	0' to 100'

The Standard shall be used unless engineering judgement determines that another dimension within the range is more suitable for a particular site or special condition and is approved by Livingston County Road Commission.

NOTE: Concrete curb is optional on approaches to unimproved county roadways.

# Gravel Private Road Approach on Gravel County Road

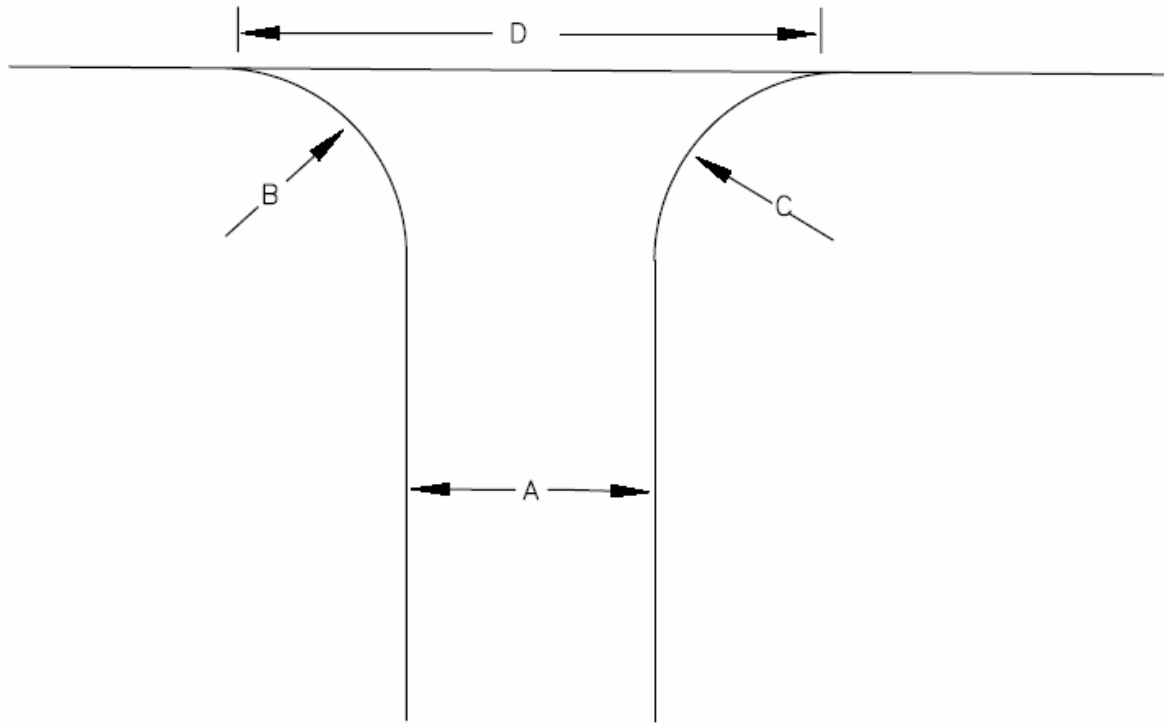

Design Feature		Standard	Range
A	Driveway Width	30'	22' to 40'
B	Entering Radius	35'	25' to 40'
C	Existing Radius	35'	25' to 40'
D	Total Opening (A+B+C)	100'	72' to 120'

**The Standard shall be used unless engineering judgement deems that another dimension within the range is more suitable for a particular site or special condition and is approved by Livingston County Road Commission.**

# Paved Road Approach on Gravel County Road

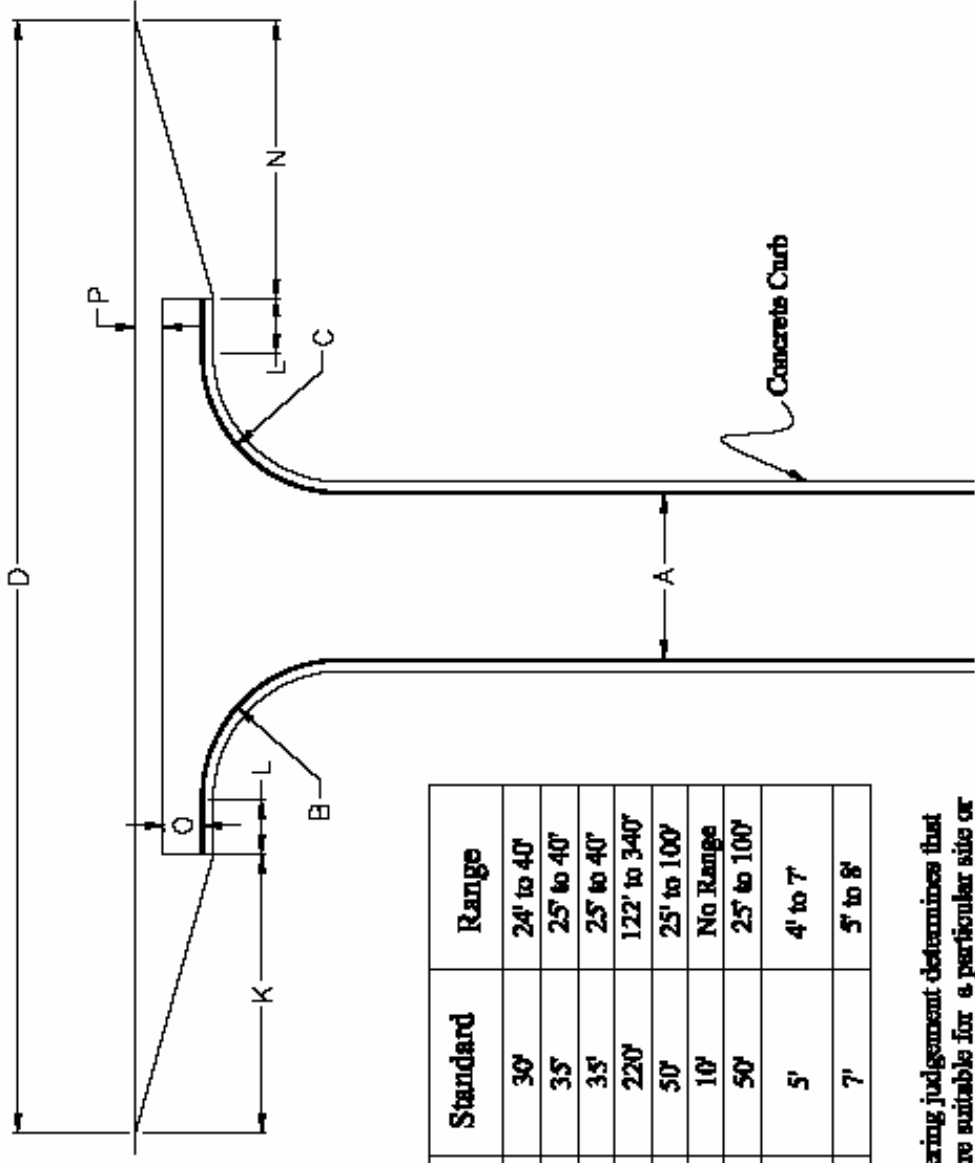

Design Feature	Standard	Range
A Driveway Width	30'	24' to 40'
B Entering Radius	35'	25' to 40'
C Belting Radius	35'	25' to 40'
D Total Opening	220'	122' to 340'
K Entering Taper	50'	25' to 100'
L Curb Footing	10'	No Range
N Belting Taper	50'	25' to 100'
O Pavement Width at Radius Springpoint	5'	4' to 7'
P Pavement Offset	7'	5' to 8'

The Standard shall be used unless engineering judgement determines that another dimension within the range is more suitable for a particular site or special condition and is approved by Livingston County Road Commission.

NOTE: Concrete curb is optional on approaches to uncurbed county roadways.

# Paved Road Approach on Paved County Road

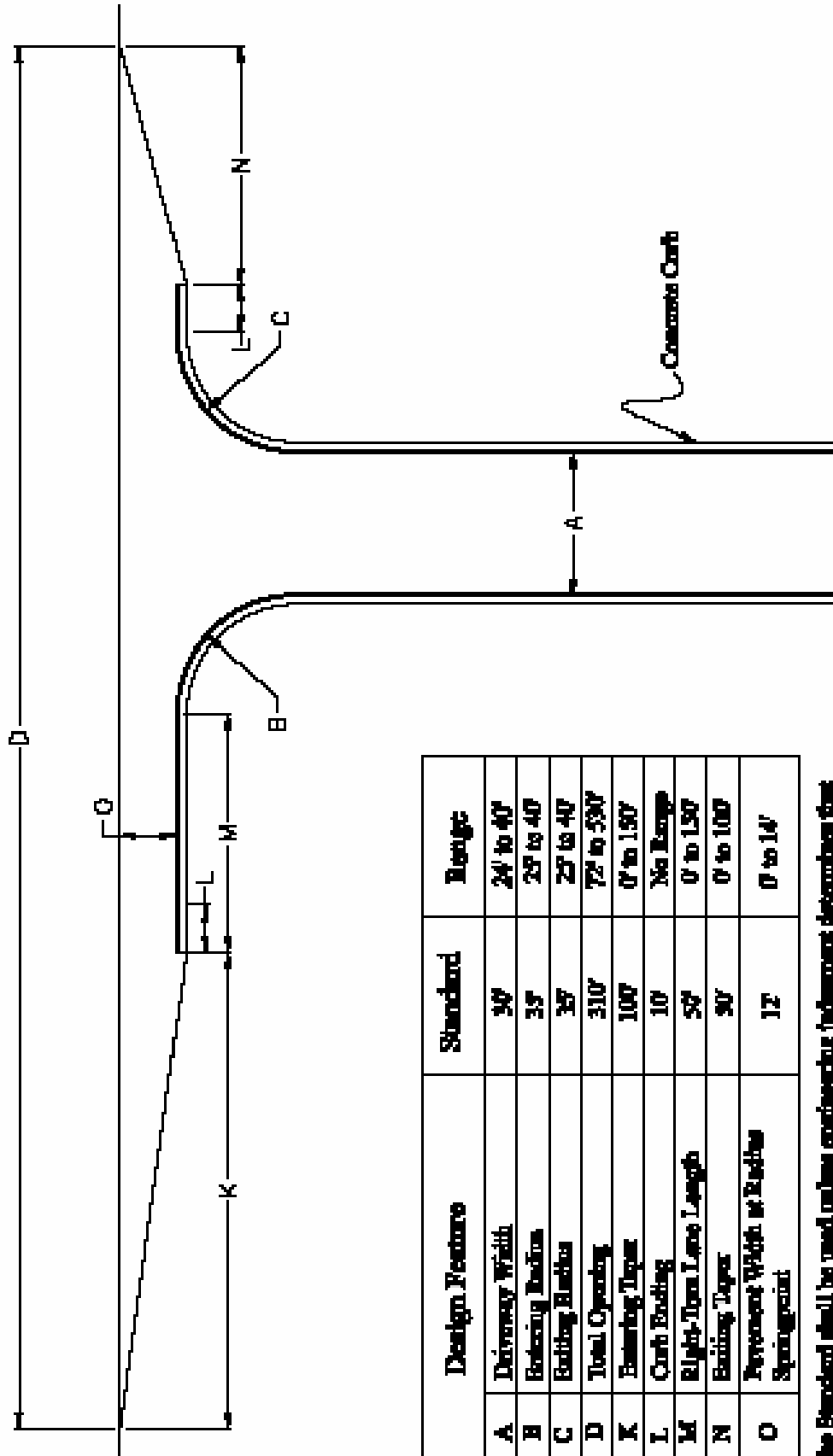

Design Feature	Standard	Range
A	30'	24' to 40'
B	35'	25' to 40'
C	35'	25' to 40'
D	310'	72' to 530'
K	100'	0' to 150'
L	10'	No Range
M	50'	0' to 150'
N	50'	0' to 100'
O	12'	0' to 14'

The Standard shall be used unless engineering judgment determines that another dimension within the range is more suitable for a particular site or special condition and is approved by Livingston County Road Commission.

**NOTE:** Concrete curb is optional on approaches to uncurbed county roadways.

# Divided Paved Road Approach on Paved County Road

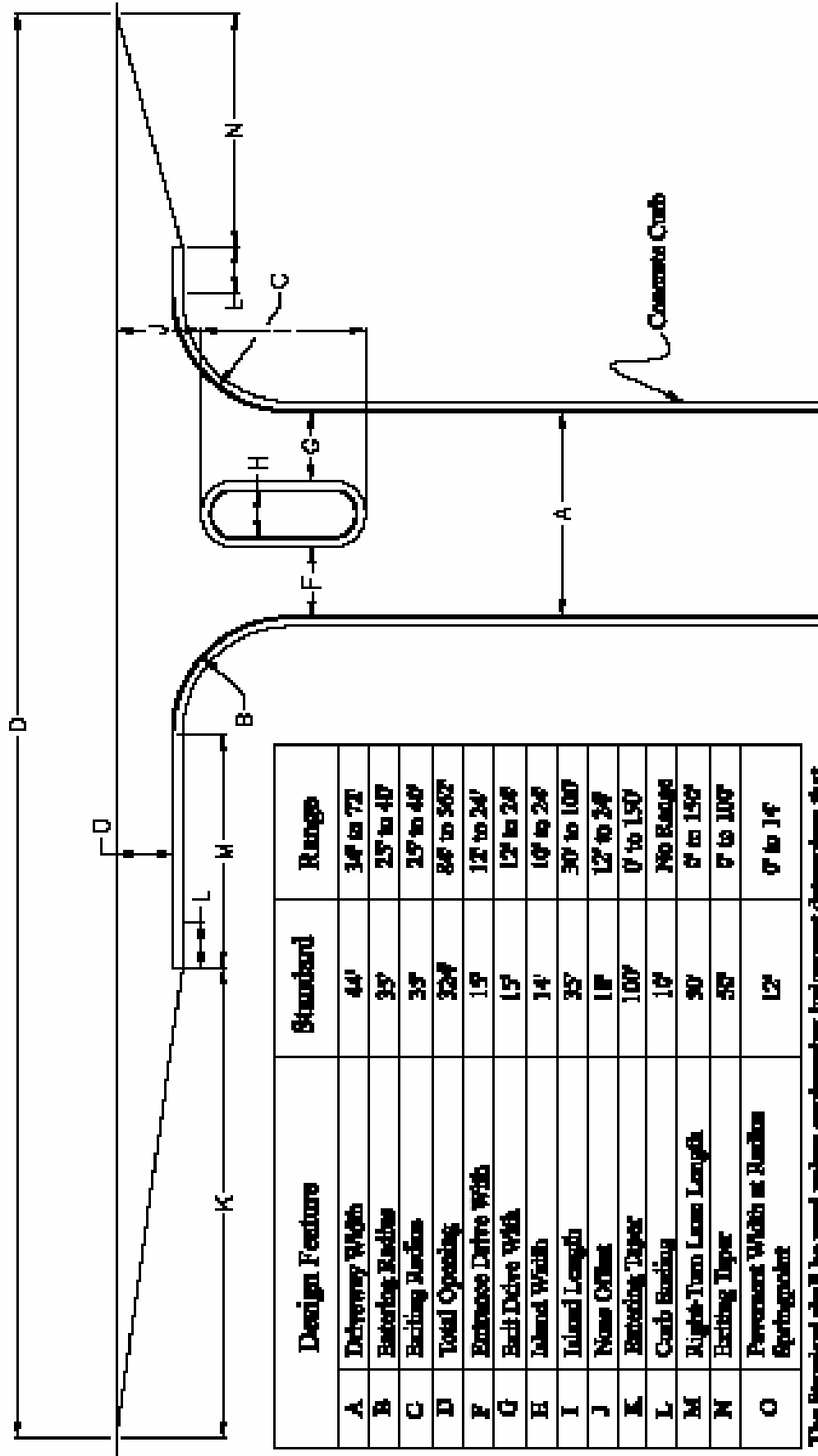

Design Feature	Standard	Range
A	44'	34' to 72'
B	25'	25' to 40'
C	25'	25' to 40'
D	32'	24' to 50'
E	15'	12' to 24'
F	15'	12' to 24'
G	14'	10' to 24'
H	32'	30' to 100'
I	18'	12' to 24'
J	100'	0' to 150'
K	10'	No Range
L	30'	0' to 150'
M	50'	0' to 100'
N	12'	0' to 14'
O		

The Standard shall be used unless engineering judgment determines that another dimension within the range is more suitable for a particular site or special condition and is approved by Livingston County Road Commission.

NOTE: Concrete curb is optional on approaches to unimproved county roadways.

## Left-Turn Passing Lane

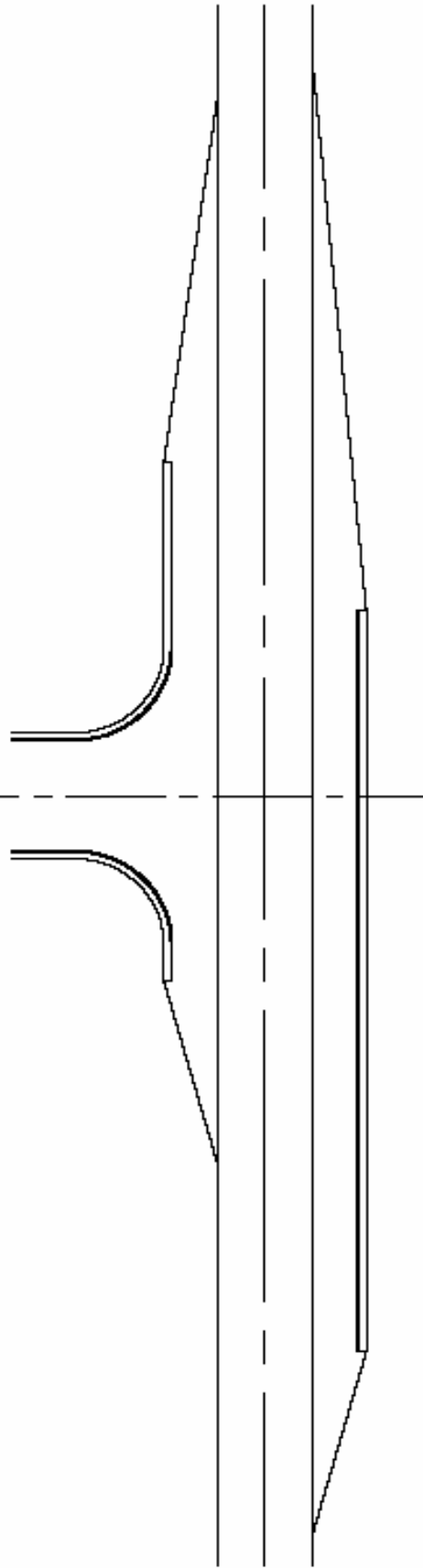

Design Feature		Standard	Range
L	Curb Height	10"	No Range
Q	Passing Lane Approach Taper	150'	100' to 250'
R	Passing Lane Approach Length	150'	100' to 250'
S	Passing Lane Departing Length	50'	50' to 100'
T	Passing Lane Departing Length	150'	100' to 250'

The Standard shall be used unless engineering judgement determines that another dimension within the range is more suitable for a particular site or special conditions and is approved by Livingston County Road Commission.

NOTE: Concrete curb is optional on approaches to uncurbed rotary roundabouts.

**WARRANTS FOR LEFT TURN  
PASSING LANE  
(BASED ON TOTAL DEVELOPMENT)**

